

SPECIFICATIONS

Model	Recommended Amplifier Power	Normal Impedance	Frequency Response	Sensitivity	Frame Dimensions	Hole Cut-Out Dimensions	Depth Behind Ceiling
CM710 7" polypropylene woofer with treated urethane surround and one fluid-cooled 13mm Kaladex.	10 to 100 watts per channel	8 ohm nominal; 6 ohm minimum	59Hz - 20kHz +/-3dB	91 dB with 2.83 V pink noise input measured at 1 meter on axis	9-1/4 inches	8 inches	4-3/8 inches
CM730 7" polypropylene woofer with treated urethane surround and one fluid-cooled 13mm Kaladex.	10 to 100 watts per channel	8 ohm nominal; 6 ohm minimum	59Hz - 21kHz +/-3dB	91 dB with 2.83 V pink noise input measured at 1 meter on axis	9-1/4 inches	8 inches	4-3/8 inches
CM750 7" polypropylene woofer with treated urethane surround and one fluid-cooled 13mm Kaladex.	10 to 125 watts per channel	8 ohm nominal; 6 ohm minimum	56Hz - 21kHz +/-3dB	91 dB with 2.83 V pink noise input measured at 1 meter on axis	9-1/4 inches	8 inches	4-3/8 inches
CM760 7" polypropylene woofer with treated urethane surround and one fluid-cooled 13mm Kaladex.	10 to 150 watts per channel	8 ohm nominal; 6 ohm minimum	54Hz - 21kHz +/-3dB	91 dB with 2.83 V pink noise input measured at 1 meter on axis	9-1/4 inches	8 inches	4-3/8 inches

TECHNICAL SUPPORT

IF YOU HAVE QUESTIONS ABOUT THE INSTALLATION OR OPERATION OF THIS OR ANY OTHER NILES PRODUCT, PLEASE CALL OUR TECHNICAL SUPPORT DEPARTMENT AT 1-800-BUY-HIFI (1-800-289-4434). SUPPORT IS AVAILABLE WEEKDAYS 8:00 A.M. TO 7:00 P.M. EASTERN TIME WITH THE EXCEPTION OF HOLIDAYS.

LIMITED WARRANTY

NILES AUDIO CORPORATION ("NILES") WARRANTS ITS LOUDSPEAKER PRODUCTS TO THE ORIGINAL PURCHASER TO BE FREE OF MANUFACTURING DEFECTS IN MATERIAL AND WORKMANSHIP FOR A PERIOD OF FIVE YEARS FROM DATE OF PURCHASE.

THIS WARRANTY IS SUBJECT TO THE FOLLOWING ADDITIONAL CONDITIONS AND LIMITATIONS. THE WARRANTY IS VOID AND INAPPLICABLE IF NILES DEEMS THAT THE PRODUCT HAS BEEN USED OR HANDLED OTHER THAN IN ACCORDANCE WITH THE INSTRUCTIONS PROVIDED BY THE MANUFACTURER, INCLUDING BUT NOT LIMITED TO DAMAGE CAUSED BY ACCIDENT, MISHANDLING, IMPROPER INSTALLATION, ABUSE, NEGLIGENCE, OR NORMAL WEAR AND TEAR, OR ANY DEFECT CAUSED BY REPAIR TO THE PRODUCT BY ANYONE OTHER THAN NILES OR AN AUTHORIZED NILES DEALER.

TO OBTAIN WARRANTY SERVICE, TAKE THE UNIT TO THE NEAREST AUTHORIZED NILES DEALER, WHO WILL TEST THE PRODUCT AND IF NECESSARY, FORWARD IT TO NILES FOR SERVICE. IF THERE ARE NO AUTHORIZED NILES DEALERS IN YOUR AREA, YOU MUST WRITE TO NILES AND INCLUDE YOUR NAME, ADDRESS, MODEL AND SERIAL NUMBER OF YOUR UNIT, ALONG WITH A BRIEF DESCRIPTION OF THE PROBLEM. A FACTORY RETURN AUTHORIZATION NUMBER WILL BE SENT TO YOU. DO NOT RETURN ANY UNIT WITHOUT FIRST RECEIVING WRITTEN AUTHORIZATION AND SHIPPING INSTRUCTIONS FROM NILES.

IF THE ABOVE CONDITIONS ARE MET, THE PURCHASER'S SOLE REMEDY SHALL BE TO RETURN THE PRODUCT TO NILES, IN WHICH CASE NILES WILL REPAIR OR REPLACE, AT ITS SOLE OPTION, THE DEFECTIVE PRODUCT WITHOUT CHARGE FOR PARTS OR LABOR. NILES WILL RETURN A UNIT REPAIRED OR REPLACED UNDER WARRANTY BY SHIPPING SAME BY ITS USUAL SHIPPING METHOD FROM THE FACTORY (ONLY) AT ITS EXPENSE WITHIN THE UNITED STATES OF AMERICA. THERE ARE NO OTHER WARRANTIES, INCLUDING WITHOUT LIMITATION, EITHER EXPRESS OR IMPLIED WARRANTIES OF MERCHANTABILITY OR FITNESS FOR A PARTICULAR PURPOSE, WITH RESPECT TO THE PRODUCT.

REPAIR OR REPLACEMENT AS PROVIDED UNDER THIS WARRANTY IS THE EXCLUSIVE REMEDY OF THE CONSUMER/PURCHASER. NILES SHALL NOT BE RESPONSIBLE FOR ANY INCIDENTAL OR CONSEQUENTIAL DAMAGES EXCEPT TO THE EXTENT PROVIDED (OR PROHIBITED) BY APPLICABLE LAW.

SOME STATES DO NOT ALLOW THE EXCLUSION OR LIMITATION OF INCIDENTAL OR CONSEQUENTIAL DAMAGES, SO THE ABOVE LIMITATION MAY NOT APPLY TO YOU. THIS WARRANTY GIVES YOU SPECIFIC LEGAL RIGHTS, AND YOU MAY ALSO HAVE OTHER RIGHTS WHICH VARY FROM STATE TO STATE.

FOR THE NAME OF YOUR NEAREST AUTHORIZED NILES DEALER CONTACT:
NILES AUDIO CORPORATION, P.O. BOX 160818, MIAMI, FLORIDA 33116-0818.



BLENDING HIGH FIDELITY AND ARCHITECTURE®

Niles Audio Corporation
12331 S.W. 130 Street Miami, Florida 33186
Phone: 305-238-4373 Fax: (305) 238-0185
www.nilesaudio.com

©2007 Niles Audio Corporation. All rights reserved. Niles and the Niles logos are registered trademarks of Niles Audio Corporation. All other trademarks are the property of their respective owners. DS00525A

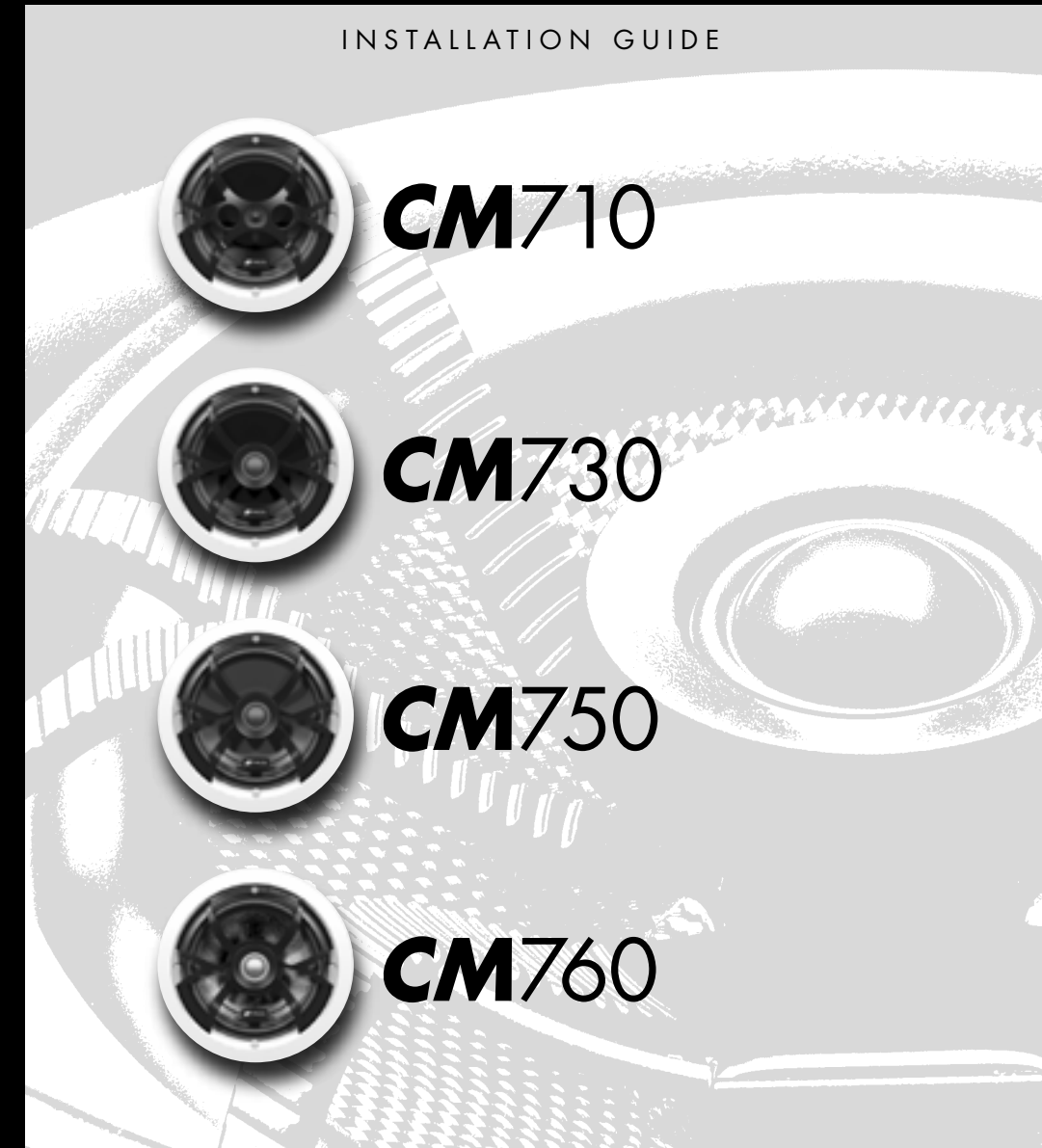
INSTALLATION GUIDE

CM710
CM730
CM750
CM760
HIGH PERFORMANCE CEILING LOUDSPEAKERS

CONGRATULATIONS!

Thank you for choosing a CM710, CM730, CM750 or CM760 loudspeaker from Niles. With proper installation and operation, you will enjoy years of trouble-free use. Niles manufactures the industry's most complete line of custom installation components and accessories for audio/video systems. To see the complete Niles product assortment, visit us on the Internet at: www.nilesaudio.com

PACKAGE CONTENTS

One pair of CM710, CM730, CM750 or CM760 loudspeakers; 1 pair of Aluminum MicroPerf® Grilles and 1 pair of cardboard paint mask/ hole cutout templates.

INSTALLATION CONSIDERATIONS

We recommend using the following tools and material to install your Niles CM loudspeaker:

- Cordless drill with 1/4 – and 1/2-inch drill bits and a 1-inch paddle drill bit (for drilling through studs)
- Keyhole or drywall saw
- Phillips screwdriver set
- Stiff wire, fish tape or glow rods for routing cables
- Wire stripper
- Stud finder
- Rubber gloves and protective eyewear
- Cable ties
- Pencil

Before starting the installation, please observe the following precautions:

- Turn off all system power before making any connections
- Make sure hands are clean before installation
- Always wear protective eyewear when using tools
- Wear gloves when working with fiberglass insulation

RUNNING WIRES IN WALLS OR CEILINGS

When running loudspeaker wire inside walls or ceilings, use special jacketed cable (a minimum of 18 to 16-gauge two-conductor CL-2 or CL-3 rated loudspeaker wire) to protect the wire and for fire prevention. In some areas, conduit is also required. For a trouble-free installation, low-voltage wire such as loudspeaker wire must be run in accordance with the National Electrical Code and any applicable provisions of the local building code. If you are unsure of the correct installation techniques, wire jacket, or type of conduit to use, consult a professional audio/video installer, building contractor, or the local building and inspection department.

SELECTING THE LOCATION FOR YOUR LOUDSPEAKERS

The CM700 series loudspeakers are designed to be installed in any standard ceiling. There are two considerations for placing the loudspeaker; ease of running the cable to the loudspeaker and coverage of the loudspeaker. The best stereo effect will be achieved if both the loudspeakers are at equal distance from the listener and closer together than the listener is from the loudspeakers. Avoid installing the loudspeakers near corners to prevent a “boomy” or diffracted sound. The CM700 series loudspeakers will cover an area of a circle with a 16-foot diameter when mounted at an 8-foot height. (See **Figure 1**)

EXISTING CONSTRUCTION INSTALLATION

IMPORTANT: BEFORE YOU CUT INTO ANY WALL, REVIEW THE PRIOR SECTION ON LOUDSPEAKER PLACEMENT WHEN SELECTING THE LOCATION FOR YOUR LOUDSPEAKERS.

- When determining the location of the loudspeaker cutout, keep in mind that the mounting dogs will extend 3/4” beyond the cutout. Make sure that you do not place the edge of the cutout directly next to a ceiling joist. Locate the joists using a stud sensor or by hand knocking. Use the supplied cutout template (remove the largest perforated circle and use cardboard square with hole as the template) to determine how large of a hole you will need to cut. These templates are packed with your loudspeakers between the styrofoam packing and the ends of the box.
- Once you have determined a possible position for the cutout, drill a 1/8” pilot hole just barely through the ceiling (1/2” to 5/8” deep in most homes) in the center of your proposed loudspeaker location.

BE VERY CAREFUL NOT TO DRILL THROUGH EXISTING WIRES, PIPES, OR STRUCTURE. IF YOU FEEL ANY EXTRA RESISTANCE AS YOU ARE DRILLING, STOP.

- Cut a foot-long piece of coat hanger. Bend the wire (creating a right angle) leaving 5-1/2” at one end (this allows for the extra width of the mounting dogs). Poke the “L-shaped” wire into the pilot hole and turn it in a complete circle and move it into the ceiling cavity to make sure you have approximately 4-3/8” of depth. If the wire’s movement is obstructed by anything, fill the hole(s) with spackle and try another location.

- If the coat hanger moves freely in a complete circle and you have sufficient depth, hold the template up to the ceiling surface. The cardboard square with the circular hole is the template. The inner perforated circle within the larger circle that was removed in step 1 earlier is the paint mask. Keep it for painting the loudspeaker later. Outline the circular cutout on the ceiling surface lightly with a pencil. Drill the starting point of your cut with a 1/4” bit.

- If you are cutting drywall use a sheetrock or keyhole saw, cut the hole with the saw at a 45° angle. That way the drywall section can be replaced cleanly if there is an unseen obstruction behind the wall.

IMPORTANT: BE VERY CAREFUL NOT TO SAW THROUGH EXISTING WIRES, PIPES, OR STRUCTURE.

IF YOU FEEL EXTRA RESISTANCE AS YOU ARE CUTTING, STOP.

NEW CONSTRUCTION INSTALLATION

INSULATING THE WALL CAVITY

If feasible, fill the wall cavity with insulation at this point.

MOUNTING THE NEW CONSTRUCTION BRACKET

The optional CM700 BKT can be used with the CM710, CM730, CM750 or CM760 loudspeakers. The hole saving bracket enables a faster and cleaner final installation of the loudspeaker. It forces the drywall installer to cut out the loudspeaker hole for you and provides wire ties for the loudspeaker wire, reducing the risks of accidental loss or movement of the wire. In addition, it enables you to align your loudspeakers with other ceiling fixtures with great accuracy since you can really see exactly where the loudspeaker will be. To install the bracket, first pivot the long wing out until it stops, which will be in straight line with the short wing. The wings and brackets have centering lines to simplify placement of the loudspeakers. Screw one side of the assembled bracket with wings to the joist using one of the supplied screws. Level the bracket. Screw the other side of the bracket/wing assembly to the joist. Two screws on each side make for a very secure installation. Secure the wire to the bracket using bracket’s wire tie tab. The drywall installers will cut the drywall to the exact size of the bracket. (See **Figure 2**)

CONCEALING LOUDSPEAKER WIRE FOR A FUTURE INSTALLATION

Attach the loudspeaker wire in a loop between the ceiling joists and carefully mark the exact location of the wire on a set of plans. Ask the general contractor to inform the drywall installers that the loudspeaker wire loops are concealed for future installations.

UNPACKING AND FINAL INSTALLATION

- Remove the top piece of styrofoam from the box. You will find two loudspeakers bagged in a lower portion of packing. Remove the loudspeaker from the bag. The metal grille is installed on the loudspeaker and will need to be removed. This is easily done by rotating the mounting “dogs” out with your fingers and pulling them towards the front of the loudspeaker. This will push the screw heads against the inside of the grille to work it out of the baffle. (See **Figure 3**)
- At each loudspeaker location, route the wire to the input connectors, then separate the loudspeaker wire so that at least 2 inches of each conductor are free. Strip away 1/4 inch of insulation from each individual loudspeaker wire.
- Press down each spring-loaded connector one at a time, insert the appropriate conductor and then release the connector. Check to be sure that the connector is making contact with stripped wire and not the wire jacket. Gently tug on the loudspeaker wire to make sure it is held in place. If not, repeat this procedure until it is.

IMPORTANT: OBSERVE CORRECT POLARITY: POSITIVE (+) GOES TO THE RED POST AND NEGATIVE (-) GOES TO THE BLACK POST.

- Rotate dogs back to their original positions so that they do not protrude out from the diameter of the loudspeaker.
- Insert the loudspeaker into the hole by carefully holding it with both hands and angling it slowly into the hole until the frame is flush with the ceiling. Holding it in place carefully with one hand, (do not push against the woofer or tweeter) use a cordless drill to begin mounting the loudspeaker.
- Tighten the four screws using a #2 Phillips bit. Use low torque and low speed or you may damage the loudspeaker. This should pull the frame and mounting dog together (sandwiching the drywall) so that the frame is absolutely flush with the wall surface. There should be no gaps between the wall and the frame.

IMPORTANT: DO NOT OVER TIGHTEN THE SCREWS! OVER TIGHTENING THEM MAY MAKE THE GRILLE DIFFICULT TO INSTALL

- Direct the tweeter. (CM730, CM750 & CM760 only) The tweeter is directed by gently pressing on the outer edge of the tweeter housing. It will move up to 20 degrees in any direction. For critical listening, direct the tweeter towards the user’s favorite listening position. For surround sound or low volume background listening, create more reflections and thus more ambiance by directing the tweeter towards the sidewalls. (See **Figure 4**)

- Set the Treble level control. (CM760 only) Listen to a well-recorded piece of music at the user’s favorite listening position. Listen for treble harshness or ringing, particularly when the loudspeakers are placed in a room without carpet. Use the -3dB Treble cut position to correct. Listen for dull or muffled upper frequencies, particularly when the loudspeakers are installed in an area with thick carpet or fabric wall coverings. Use the +3dB Treble boost position to correct. (See **Figure 5**)

- Install the MicroPerf™ grille. Start by positioning one edge of the grille slightly inside the loudspeaker. Gently work around the loudspeaker a little at a time until the grille is fully seated. Don’t try to insert the grille fully in any one area, as this will make complete installation more difficult. Don’t force the grille to fit as you may damage the grille if you apply too much force.

- Connect the other end of each loudspeaker wire to the receiver (or amplifier) carefully observing polarity.

- Turn on the receiver or amplifier and test all loudspeakers in the system.

PAINTING THE GRILLE AND FRAME

Each CM710, CM730, CM750 & CM760 loudspeaker and flush-mount metal grille may be painted without the need for primer.

- Install loudspeaker into ceiling or wall following the previous steps 1 - 7.
- Remove the smallest perforated circle from the cardboard square template. This is the paint mask that protects the loudspeaker from paint. Gently press it into place inside the baffle.
- Paint the frame of the loudspeaker.
- Paint the grille separately from the loudspeaker frame. For best results when painting the grille, use a spray gun or airless sprayer. Thin the paint to prevent clogging of the grille holes and apply several light coats instead of one heavy one.
- Gently remove the paint mask after paint has dried by pressing in the tab in the center and carefully pulling out the mask with your finger. Be very careful not to poke the tweeter with your finger.
- Finish installation of the loudspeaker following the previous steps 8 –10.

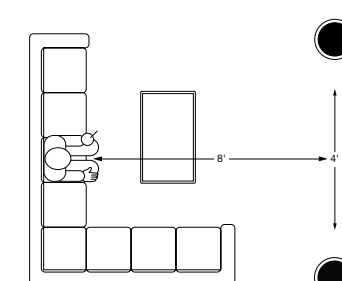

Figure 1. Typical placement for stereo listening.

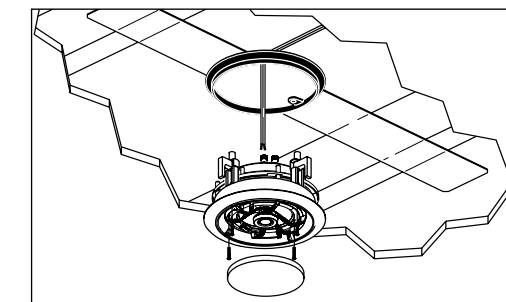

Figure 2. New construction bracket.

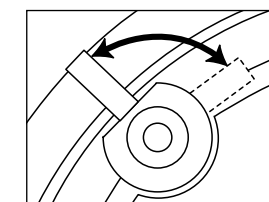

Figure 3. Mounting “dog” rotation.



Figure 4. Tweeter adjustment.



Figure 5. Treble Level Control.